



## VKV Spark arrester

### Design

The operation of the spark arrester is based on the centrifugal system. The gases are forced into a rotary movement by means of a fixed number of blades. The carbon particles in the gases are thrown against the wall of the spark arrester and collected on the soot box.

For good working of the spark arrester, it is important to take off the cap of the soot collector at regular intervals, so the soot particles in this collector can be removed. It is advisable to take off the cap already when installing the spark arrester and to connect a soot pipe to the collector, so the soot particles can be collected at a lower and usually more accessible place.

TIO spark arresters meet the requirements of PTB - GL - NSI - etc.

Degrees of spark and/or separation:

- particle size 0,5 mm = 100%
- particle size 0,2 mm = 99%
- particle size 0,1 mm = 95%

### Gas velocity

The recommended gas velocity is 35 - 50 m/sec., however also depending on the maximum allowable back pressure across exhaust system.

### Pressure loss

The graph shows the approximate pressure drop across the spark arrester in relation to the gas velocity.

If required, we can advise in detail and make computer calculations.

### Temperature

Maximum: 600°C.

Special designs are available for higher temperatures.

### Material

In- and outside - normal steel, trade quality.

Execution with other materials like stainless steel, Cor-Ten steel, possible.

### Paint

One layer of zinc phosphate primer.

### Installation

The spark arrester can be installed in horizontal or vertical position but in such a way that the soot collector is in the most suitable attitude to accept the fall out particles.

When installing at site, it is possible to weld suspensions on the body.

N.B. TIO spark arresters can be combined with all TIO silencers. Available on request: not standard finishes, materials and sizes over 24" bore.

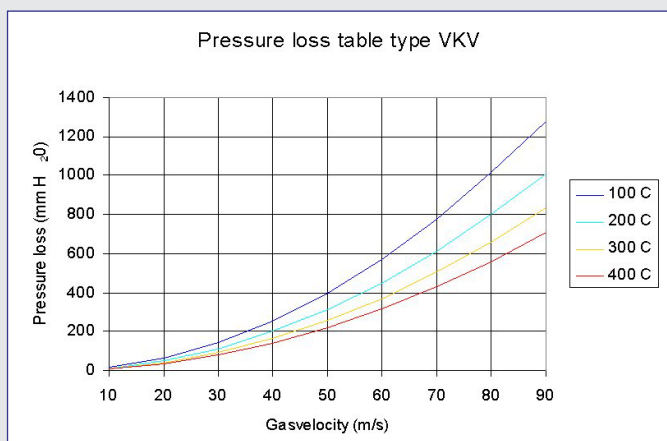

Parallelweg 9 2921 LE • PO box 701 2920 CA • Krimpen aan den IJssel The Netherlands  
 P +31 (0)180 514 055 • F +31 (0)180 517 264 • E info@tiobv.nl • www.tiobv.nl



## VKV Spark arrester

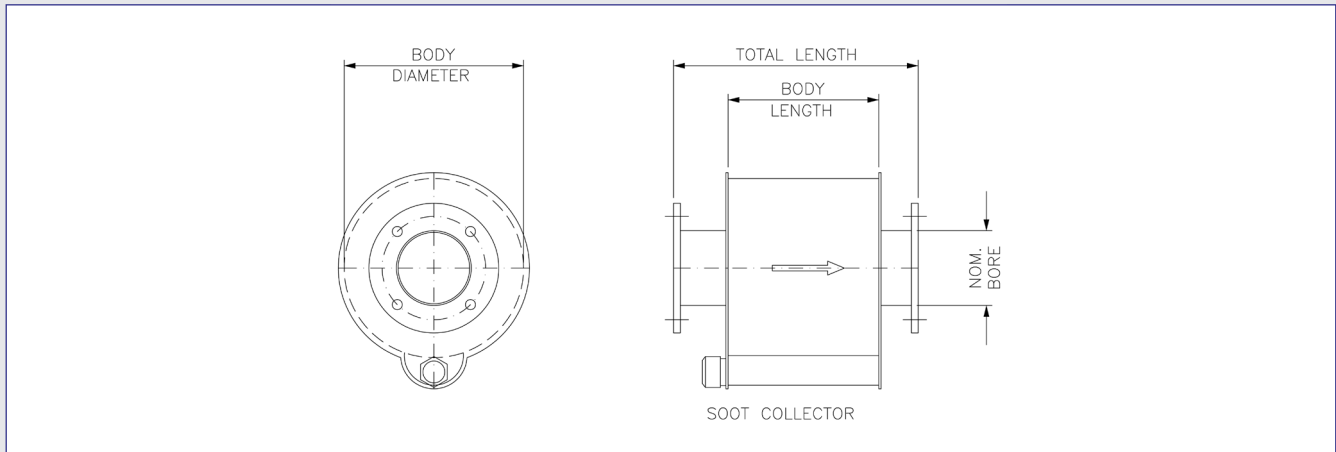

### Executions with TIO thread

Silencer type	Nominal bore	Body diameter	Body length	Total length
1"	25	110	79	156
1-1/4"	32	110	99	195
1-1/2"	40	110	99	200
2"	50	132	120	220

### Executions with TIO flanges

Silencer type	Nominal bore	Body diameter	Body length	Total length
1-1/2"	40	110	99	200
2"	50	132	120	220
2-1/2"	70	157	142	260
3"	80	180	157	285
3-1/2"	94	180	197	335
4"	100	240	210	360
5"	125	319	268	435
6"	150	370	303	490
7"	175	387	385	535
8"	200	387	430	630
9"	225	478	490	690
10"	250	570	540	740
11"	275	570	595	795
12"	300	635	700	900
13"	325	635	755	955
14"	350	700	710	1010
15"	375	700	765	1065
16"	400	750	895	1195
18"	450	800	980	1280
20"	500	900	1070	1370
22"	550	1000	1170	1470
24"	600	1100	1280	1580